

## THE DESIGN

The Revroy Brand of Boom Barrier **Model RR-TW-401 Series** is designed for toll road operation and it is for this reason that these barriers have been engineered and designed for robust and reliable operation. The simple design with soft round boom is ideal for high-speed operation demands of toll road operators & offer long reliable life. These barriers may also be used for applications other than toll that demand high speed opening & closing.

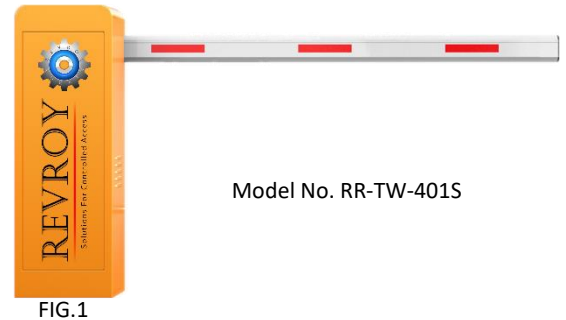

## THE DRIVE

The Brushless DC Motor forms the heart of the Boom Barrier and provides the much-needed robustness so as to offer long reliable product life cycle. This is achieved by firstly preparing the body for the Drive Mechanism to sit on a frame that is made from Aluminium Alloy manufactured by Die-Casting with attention to precise dimensions.

The Movement adopts parallel gear reduction that has high transmission efficiency and low power loss. The gear itself is made from high strength carbon steel carburised with heat treatment process, precision hobbing, anti-wear, anti-impact engineering for long service life. The Motor itself is small in size yet delivering a large output torque. The Speed is adjustable through the controller. The Movement of the boom is smooth as it accelerates and decelerates smoothly in both its open & close end positions.

## THE CONTROLLER

The controller of the REVROY Boom Barrier is all that one could ask for flexibility. When it comes to adjustment & arrangement of the functioning of the barrier it is indeed a versatile system with an array of adjustable parameters that our clients may demand, in specific to their site requirements.

Right from Boom Length adjustment combined with speed of operation for not just varied lengths but also position of braking, Varied options to engage the barrier to open and close etc., are all part of the controller settings offered for the convenience of the end user to decide, based on site conditions and demands. The System is delivered with a soft round boom arm. Loop Detector or Radar Sensor or P E Beam as an option can also be offered depending on the demands of the site.

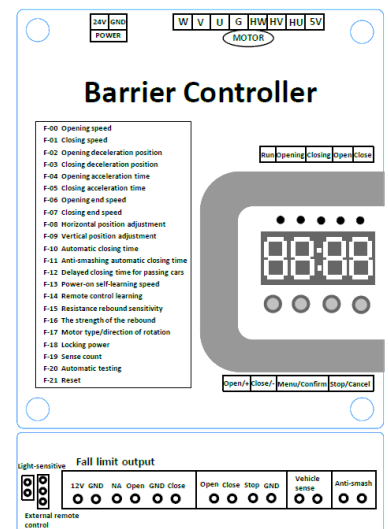

## THE DIMENSIONS

The Barrier Cabinet is fabricated in mild steel & Powder Coated in Orange. It offers IP54 protection. The dimension of the Barrier is 350 mm X 240 mm X 1050 mm. The Round Boom is extruded Aluminium so as to offer least resistance against winds. The Soft Cover is for added protection to vehicles passing through the barrier. The Octagonal Boom is 90 mm in Height & 45 mm in width.

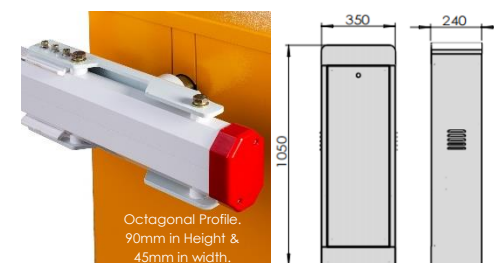

Technical Parameters	
Size	1050 X 350 X 240mm
Power Supply	220 VAC 50/60 Hz.
Open/close Speed	1.2s to 6.0s (Depending on arm length)
Working Temperature	-45°C ~ 60°C
Rated Power	140 Watts
Type of Motor	DC SERVO Motor
Motor No-load Speed	1800rpm
Output Power	56.8N.m
Humidity	≤90%
Remote Control Distance	≤100m (Open, Sunny Weather)
Protection	IP54
Max Boom Length	6M
Barrier Life Time	5 Million Cycles.
Operation During Power Failure	Manual Opening

Model No.	Type of Boom Arm	Boom Length	Opening Speed in Secs.	Closing Speed in Secs.
Model RR-TW-401S 25	Straight Arm	≤ 2500 mm	1.2	1.2
Model RR-TW-401S 30	Straight Arm	≤ 3000 mm	1.2	1.2
Model RR-TW-401S 35	Straight Arm	≤ 3500 mm	2.4	2.4
Model RR-TW-401S 40	Straight Arm	≤ 4000 mm	2.4	2.4
Model RR-TW-401S 45	Straight Arm	≤ 4500 mm	5.0	5.0
Model RR-TW-401S 50	Straight Arm	≤ 5000 mm	5.0	5.0
Model RR-TW-401S 55	Straight Arm	≤ 5500 mm	6.0	6.0
Model RR-TW-401S 60	Straight Arm	≤ 6000 mm	6.0	6.0
Model RR-TW-401-AR45	Articulate or Folding Arm	≤ 4500 mm	6.0	6.0
Model RR-TW-401-FA45	Arm with fence	≤ 4500 mm	6.0	6.0

## WARRANTY

The Barriers come with a warranty of One Year from the date of Invoice or 18 Months from the date of Installation (which-ever earlier) against manufacturing defect.

## SERVICE & INSTALLATION SUPPORT

Service & Installation support can be offered through our "Tech Support" partners. Do request for such support. However, must be raised with the Technical Support Team @ REVROY.

## BARRIER CABINET

Barrier Cabinets are orange in Colour. However, Special Colours may also be offered at Additional Cost depending on the colour.

FIG.6



## BOOM



The octagonal profile Booms are aluminium extrusions powder coated White in Colour with Red Reflective Tapes for better visibility. The Booms may be offered in various types to suite application and area of installation.

## TYPES OF BOOM ARMS

Barriers with fence Arm also known as Boom Skirt may be offered for arms not longer than 4500mm. Similarly for applications that demand a folding Arm also known as an articulated arm for areas where the Ceiling height is less than the width of the road/drive-way these barriers can be deployed.

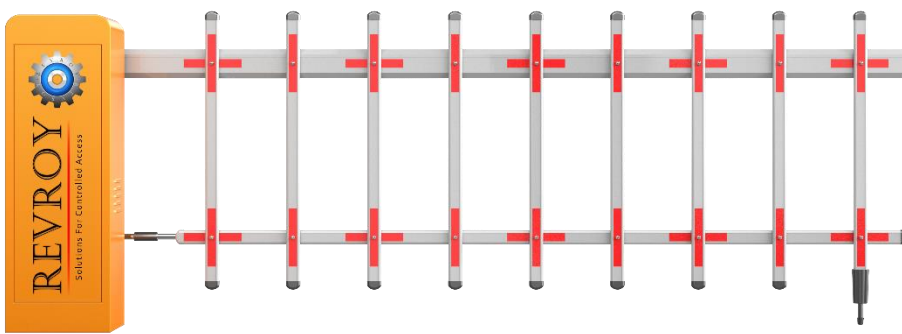
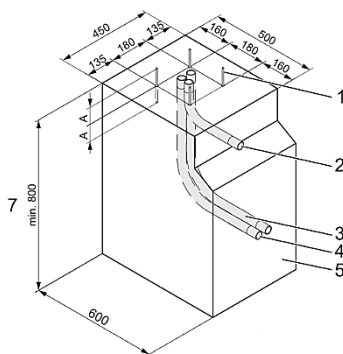

FIG.7



FIG.8

## FOUNDATION DETAILS



1. Fixing bolts (4 pcs)
2. 29mm diameter cable tube for inductive coil wire
3. 29mm diameter cable tube for power wire
4. 29mm diameter cable tube for controller wire
5. Concrete basement (BH PC250, strength = 25N / mm<sup>2</sup>)

1. The concrete in the foundation is BH PC 250 grade concrete (strength 25N/m<sup>2</sup>).
2. The base surface must be smooth so that the barrier machine case can be level and horizontally installed on it. After the concrete has been poured, the fixing screw holes can be drilled on the base surface according to the position shown on picture.
3. Drilling distance: 170mm (square arrangement, see picture).
4. Hole diameter: 16mm Hole depth: 100mm
5. After drilling the hole, install the four M16 × 150 set fixed screws in four holes.

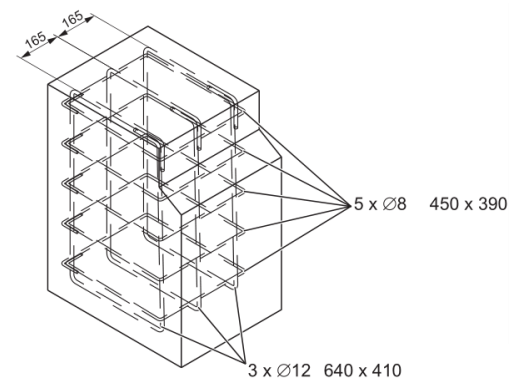



# REVROY

Solutions For Controlled Access

## CONTACT

Ravi@revroy.com | Info@revroy.com

+91 080 41302021, +91 080 41571225, +91 9840294082

### SALES OFFICE

No.#13, Hamdh Court Building,  
Mother Teresa Road, Austin Town,  
Bangalore-560 047, India

### FACTORY

Plot No 143-B, Bommasandra Industrial Area  
Bangalore-560099, Karnataka. India.  
+91 80 41658921

“Finest from the very best from around the world”



[www.revroy.com](http://www.revroy.com)